

# DC Gear Motor

# 1.61.065.XXX

**Type 1.61.065.XXX**

V =	XXX	Characteristics*				max.	Terminal	Stages	Gear
		Rated current	Rated torque	Rated speed	No load speed	Torque*	resistance		ratio
		$I_N$ / A	$T_N$ / mNm	$n_N$ / rpm	$n_o$ / rpm	$T_{max}$ / mNm	$R_a$ / $\Omega$		
6 V	403	0.330	45	136	190	63	6.5	4	27.4
	404	0.330	90	64	91	126	6.5	5	56.6
	405	0.280	150	34	44	210	6.5	6	116.9
	406	0.240	200	18	22	280	6.5	7	241.5
	407	0.170	200	9.5	10.5	280	6.5	8	499.2
	408	0.170	300	4.6	5.1	420	6.5	9	1031.6
12 V	423	0.170	45	136	190	63	27	4	27.4
	424	0.170	90	64	91	126	27	5	56.6
	425	0.140	150	34	44	210	27	6	116.9
	426	0.120	200	18	22	280	27	7	241.5
	427	0.075	200	9.5	10.5	280	27	8	499.2
	428	0.075	300	4.6	5.1	420	27	9	1031.6
18 V	443	0.120	45	136	190	63	61	4	27.4
	444	0.120	90	64	91	126	61	5	56.6
	445	0.100	150	34	44	210	61	6	116.9
	446	0.080	200	18	22	280	61	7	241.5
	447	0.065	200	9.5	10.5	280	61	8	499.2
	448	0.065	300	4.6	5.1	420	61	9	1031.6
24 V	463	0.090	45	136	202	63	93	4	27.4
	464	0.090	90	64	97	126	93	5	56.6
	465	0.080	150	34	47	210	93	6	116.9
	466	0.065	200	18	23	280	93	7	241.5
	467	0.044	200	9.5	11	280	93	8	499.2
	468	0.044	300	4.6	5.1	420	93	9	1031.6

**Operational conditions**

Temperature range	T	°C	-10 - +70
Axial force	$F_A$	N	15
Radial force, 5 mm from mounting surface	$F_R$	N	40

\* at 25° C

Design	
Weight	150 g
Gear housing	Zinc die-cast
Commutator	Copper / 3-segments
RFI protection	VDR
Insulation class	Winding F, otherwise A
Protection class	IP20
Commutation	carbon brushes
Armature	straight slot
Magnet system	Permanent magnets, 2-pole
Bearings	2 sintered bronze bearings
Motor housing	Steel, corrosion protected
Motor end shields	brush end plastic drive end zinc die-cast
Spur gear	Metal and plastic gears
Axial play output shaft	0.05 - 0.6 mm

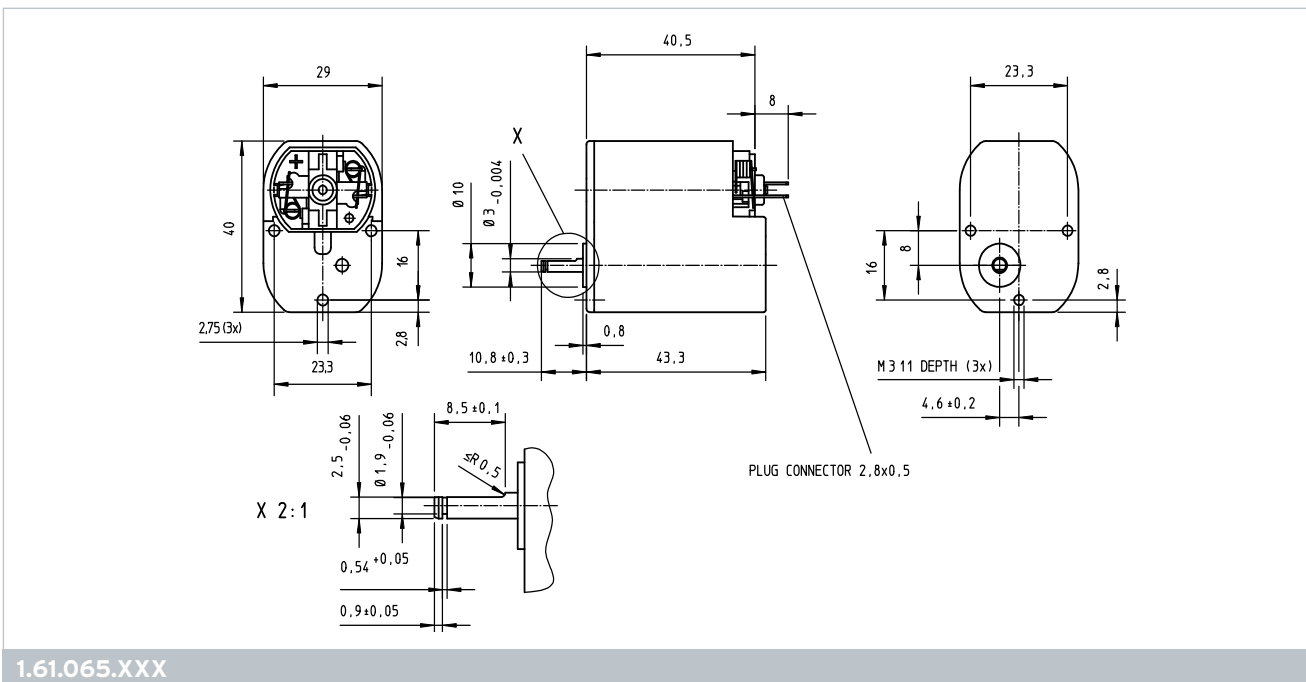

### Customized versions

The following modifications are available upon request:

- ▶ Speed adjustment by winding change
- ▶ Addition of wire harnesses
- ▶ Modification of shaft length
- ▶ Modification of shaft configuration (flat, groove, etc.)
- ▶ Assembly of gears, pinions, etc.
- ▶ Assembly of adapters and mounting plates
- ▶ Gear ratios  $i=6.4 / 10.2 / 2132$  and 4406 on request